



**TELESCOPIC HANDLER  
OPERATOR SAFETY TRAINING**

**SAMPLE**

## VARIABLE REACH TELESCOPIC HANDLER



OBJECTIVE: This training program is focused on this type of telescopic handler.

## IMPORTANCE OF TELESCOPIC HANDLER OPERATOR SAFETY TRAINING

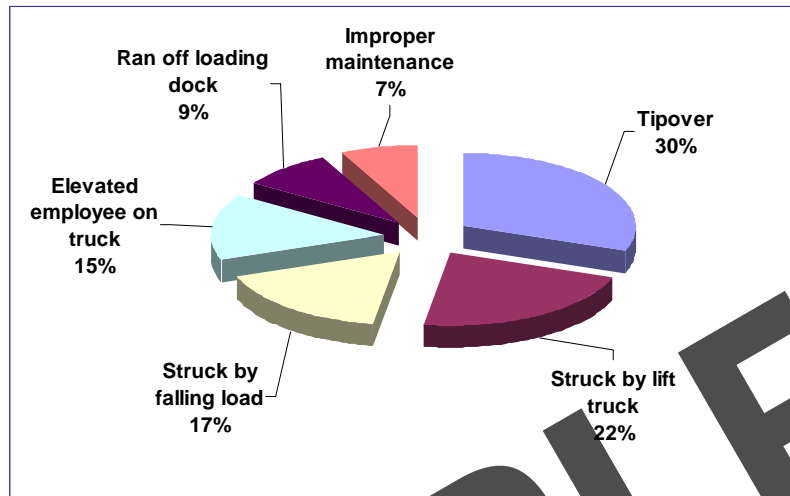

**PURPOSE:** Help the student understand why this training is vital. Introduce the need for this type of training. Create an interest in the subject.

- For each category of accident give an example or two that is relative to your workplace.

**Examples:**

**What causes a telescopic handler to tip over?**

- The most common causes of tip over is going around a corner too fast without a load.
- Turning with the forks above travel height, loaded or unloaded.
- Handling a load that is too heavy for the telescopic handler does not cause as many tipovers as one might think. Why? Because when engaging the load, the telescopic handler “gets light” and we learn to keep such a load close to the ground.

**What are the most common reasons for being struck by a telescopic handler?**

- Driving with the load obstructing your vision.
- Turning and not watching the rear end swing of the telescopic handler.
- Backing up.

For actual examples of telescopic handler accidents, go to:

<http://www.osha.gov/cgi-bin/inv/inv1sr?query=Industrial+Truck&querytp=KEYW>

**Refer to quiz on page 2 of the student manual. Take turns answering the questions.**

## WHAT IS A PROFESSIONAL?

- **You've carefully thought out all the angles.**
- **You've done it a thousand times.**
- **It comes naturally to you**
- **You know what you're doing, its what you've been trained to do your whole life.**
- **Nothing could possibly go wrong.**



**PURPOSE:** To instill in the student the importance of being a professional.

This slide and the next are meant to be humorous. They illustrate the suddenness of accidents even to the most experienced professional. It is human nature to think that "it will never happen to me." This can be dangerous in the long run.

## Think Again.



### Comment:

“Accidents that cause injuries and death come suddenly and everyone is left scratching their heads and wondering what went wrong. Usually it is because they have been cutting safety corners for years and the “odds” finally caught up to them. After the accident it becomes evident that they weren’t being as safe as they thought they were.

**“How safe are we being?”**

## Captain E. J. Smith - 1907

“When anyone asks me how I can best describe my experience of nearly forty years at sea, I merely say uneventful....(I)n all my experience I have never been in any accident of any sort worth speaking about. I have seen but one vessel in distress in all my years at sea...I never saw a wreck and never have been wrecked, nor was I ever in any predicament that threatened to end in disaster of any sort.”

Captain Smith became the captain of the Titanic in 1912



- You may wish to cover the bottom portion of this slide and let the class try and guess who this person is.
- This is a more serious version of the last slide. Here was a person that was a professional in every sense of the word but because of some mistakes on his last voyage his name and ship will always be infamous.
- You might ask what some of the mistakes were that caused the disaster:
  - Icebergs that far south were uncommon for that time of year.
  - Desire to set a record for crossing the Atlantic Ocean.
  - False sense of security that the Titanic was “unsinkable.”
  - Not enough life rafts.



## WHAT IS A PROFESSIONAL?

- Responsible
- On Time
- Rested, Alert
- Physically Prepared
- Knowledgeable
- Wears Protective Clothing
- Gets Along with Others
- Uses Safety Equipment
- Desire to Learn
- Skilled, Works to Improve
- Controls Vehicle
- Team Player

**PURPOSE:** Describe the professional telescopic handler operator.

- Discuss each item and give an example or two to explain each point. Personal examples are best, but avoid relating incidents from the workplace which may embarrass individuals.
- You may wish to ask everyone to think of a professional athlete that is admired not only for his or her ability in their sport but as human beings also. (Michael Jordan, Tiger Woods, etc.)
- What sets them apart from others?
- Have you ever worked with someone that is a joy to work with?
- What sets them apart from others?

## TELESCOPIC HANDLER VS. AUTOMOBILES

### TELESCOPIC HANDLER

- Not for personal use
- Weighs more than 5,000 lbs
- Rear wheel steering
- Training required
- Operates on various surfaces

### AUTOMOBILES

- For personal use
- Weighs less than 5,000 lbs
- Front wheel steering
- Training required
- Operates on paved roads



**PURPOSE:** Emphasis the unique characteristics of telescopic handlers. *This can be accomplished by comparing the differences and similarities between automobiles and telescopic handlers.*

- Telescopic handlers should *never* carry passengers.
- Telescopic handlers are heavy. They are easily 2 or 3 times heavier than a automobile.
- The most significant difference is that a telescopic handler has rear wheel steering. The steering wheels can pivot almost 180 degrees. *Emphasis that this feature is what gives the telescopic handler its unique maneuverability.*
- Depending on the type of tires and chassis design, the telescopic handler can operate on different surfaces.

## OPERATOR'S MANUAL

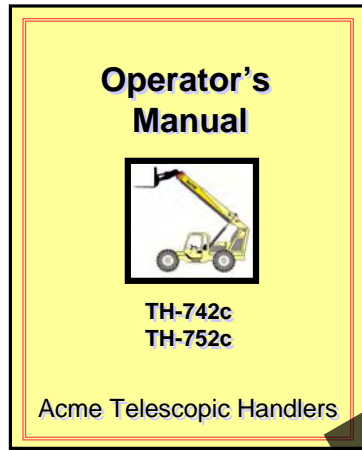

**PURPOSE:** Operator and Maintenance Manual is required to be on-board for each lift.

- The operator is required to have read and understand the Operator and Maintenance Manual prior to making a lift.
- Remind the operator that the manual is to remain on the telescopic handler.
- Use the Operator and Maintenance Manual for the daily/shift inspections.

## SIGNAL WORDS



Indicates imminently hazardous situation. If not avoided will result in death or serious injury.



Indicates potentially hazardous situation. If not avoided could result in death or serious injury.



Indicates potentially hazardous situation. If not avoided may result in minor or moderate injury.



OBJECTIVE: To acquaint the students with the significance of these three words when used as a warning.

1. All telescopic handlers will display these words along with a message about a potential injury situation.
2. Encourage the students to see where the different warnings are on the machine they are operating, what can cause the accident and how to avoid it.

## SAFETY DECALS

**Safety Decals Must Be Legible And Kept Intact As Provided By The Manufacturer. Illegible Labels Need To Be Replaced.**



OBJECTIVE: To emphasize the importance of safety decals.

1. All safety decals on the telescopic handlers must be present as intended by the manufacturer and must be legible.
2. Any decal that is not legible must be replaced.
3. Encourage the students not to disregard the importance of these labels.

## TELESCOPIC HANDLER TERMINOLOGY

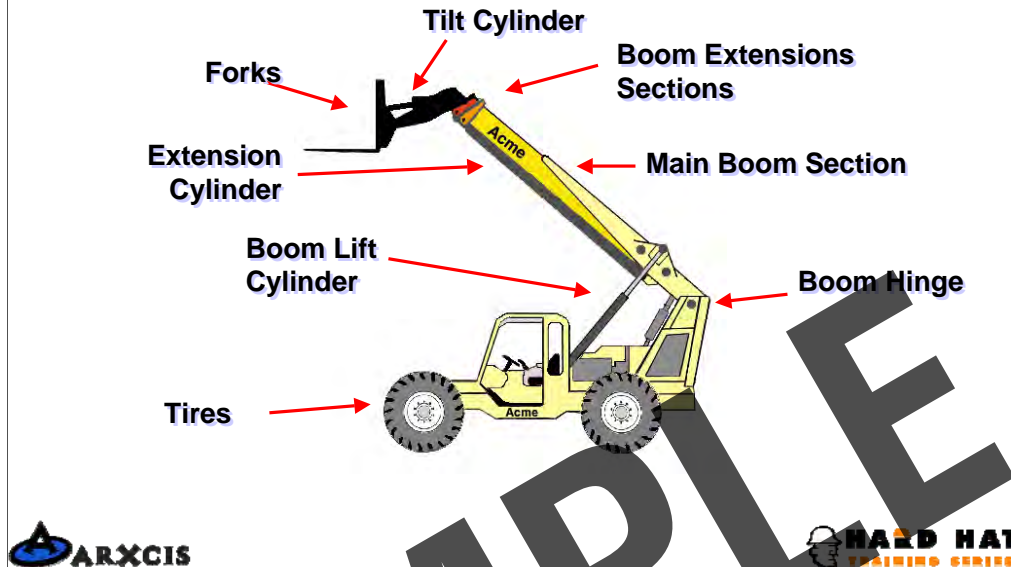

OBJECTIVE: To establish a common set of terms to be used when discussing the telescopic handler.

1. Each of these components will be discussed in more detail with subsequent slides but briefly review each component.
2. Telescopic handlers vary somewhat from manufacturer to manufacturer. If the telescopic handlers which your students will be operating are somewhat different than these, now is a good time to discuss these differences.

## PRE-OPERATION INSPECTION

### Visual Inspection

- Overall Condition
- Frame
- Tires
- Forks
- Overhead Guard
- Engine Compartment
- Electrical Equipment
- Control Labels & Markings
- Operator's Compartment



OBJECTIVE: To review the basic items which should be checked when performing the visual inspection.

1. The operator is responsible for conducting a pre-operation inspection at the beginning of each day or at the beginning of each shift.
2. Some companies provide the operator with a pre-operation check list to encourage that the inspection actually takes place.
3. Emphasize the importance of these inspections. There are a significant number of accidents which occur as a result of faulty equipment which would have been identified in the pre-operation inspection had it been performed.
4. Review each item briefly at this time and then refer back to the list when the following slides are presented.

## PRE-OPERATION INSPECTION

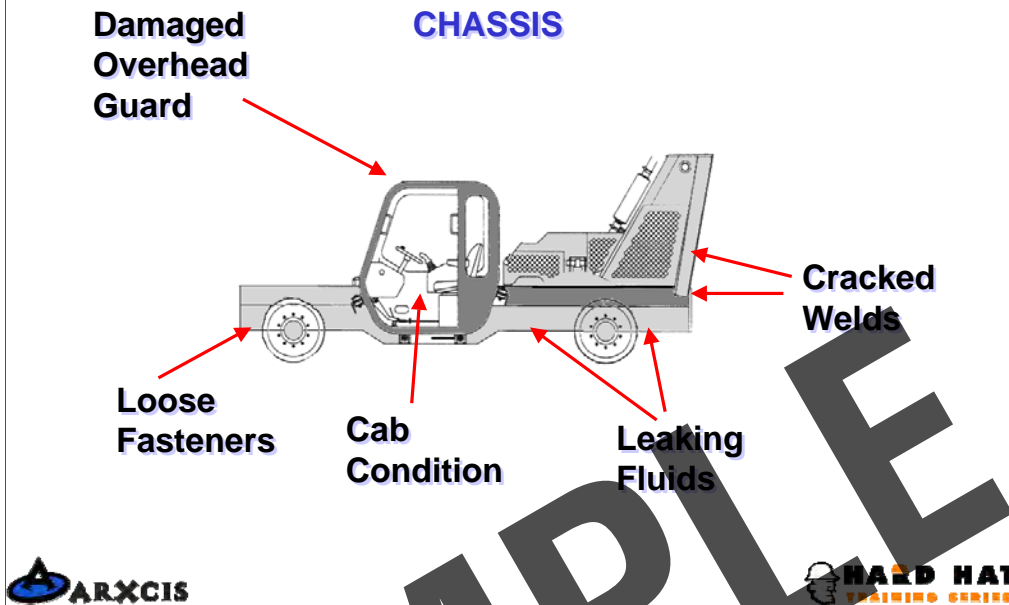

OBJECTIVE: To review the inspection points of the telescopic handlers chassis.

1. Damaged overhead guards should be repaired. Damaged guards will not adequately provide the protection necessary from falling objects.
2. Inspect the suspension system for loose bolts.
3. Cleanliness of the cab is important. Grease and mud should be removed to prevent slipping.
4. All gauges and controls along with their labels need to be clean and legible.
5. Check for leaking fluids such as fuel, coolant, hydraulic fluid and etc.
6. Check structural welds for cracks.
7. Check the engine compartment for cleanliness.

## PRE-OPERATION INSPECTION

### CHECKING FOR TIGHTNESS

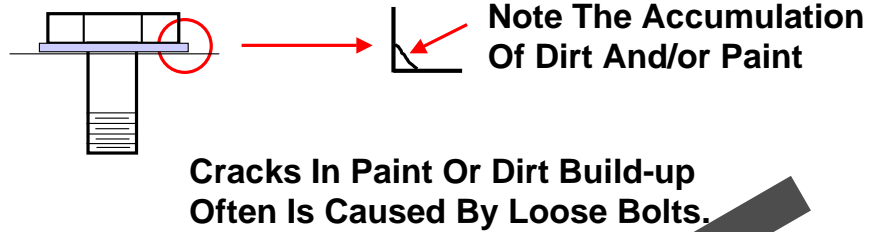

OBJECTIVE: Determining the tightness of fasteners by visual inspection.

1. Fasteners which are beginning to loosen will move very slightly under normal operations.
2. This movement can be detected by a slight crack in paint or dirt build-up between the fastener head and the machine.
3. The crack may only be a few thousands wide but if it is there, the fastener is loosening.

## PRE-OPERATION INSPECTION

### CRACKED WELDS

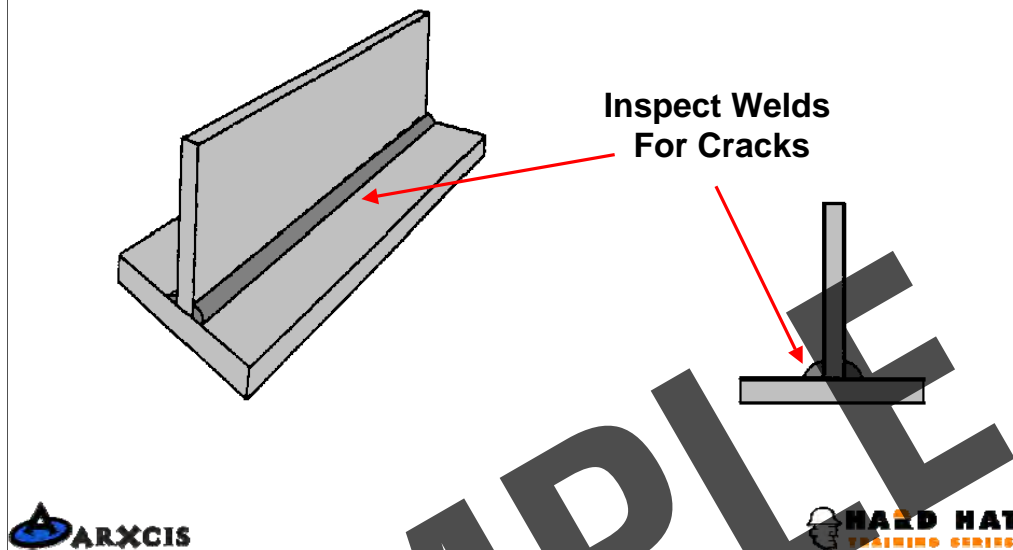

OBJECTIVE: To discuss how to identify cracked welds.

1. Cracks in paint over welded junctions could be an indicator that a weld is cracking. Investigate by removing the paint and visually inspecting the area for signs of cracking.
2. Not all cracked paint is a result of a cracked weld but the area needs to be investigated.

# PRE-OPERATION INSPECTION

## TIRES AND RIMS



### Inspect for:

- Proper Inflation
- Cuts and Gouges
- Worn Tread
- Bent Rims
- Missing Lug Nuts



OBJECTIVE: To discuss the inspection of tires and rims.

1. The stability of the telescopic handler can be effected by the inflation of the tires.
2. Tire life can be extended by proper inflation.
3. Tires with cut side walls beyond the manufacturers allowable limits need to be replaced.
4. Severely bent rims should be replaced
5. Telescopic handlers with broken or missing lug nuts/bolts should not be operated.

## PRE-OPERATION INSPECTION

### SWAY CONTROL LATERAL LEVELING

Hydraulic Cylinders  
Used to Adjust Machine  
From Side To Side

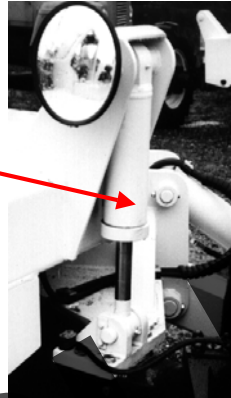

OBJECTIVE: Proper inspection of sway control cylinders.

1. The sway control cylinders should not have weeping fluid which could indicate that the cylinder may not be holding.
2. Check the mounting bolts to make sure they are intact.

## PRE-OPERATION INSPECTION

### BOOM & COMPONENTS

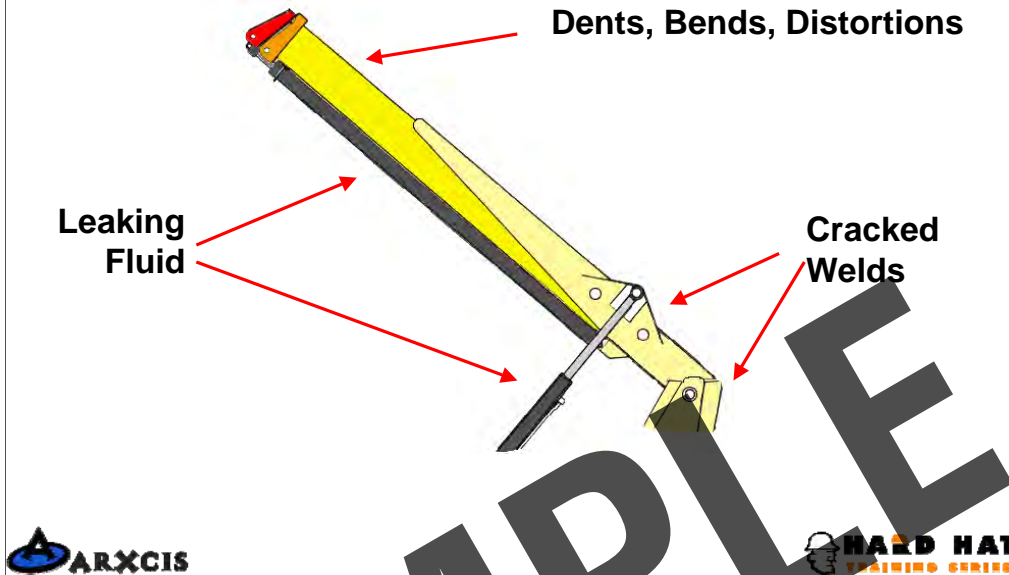

OBJECTIVE: To discuss the inspection of the boom and its components.

1. Check the hydraulic cylinders and hoses for leaks and damage.
2. With the boom extended, check for dents, bends, or other distortions. As a rule of thumb, dents over 1/8" deep need to be investigated and checked with the manufacturer.
3. Check the boom area where the lift cylinders attach for cracked welds.
4. The boom hinge pin and bosses should not be worn. Excess wear can cause a load stability problem.

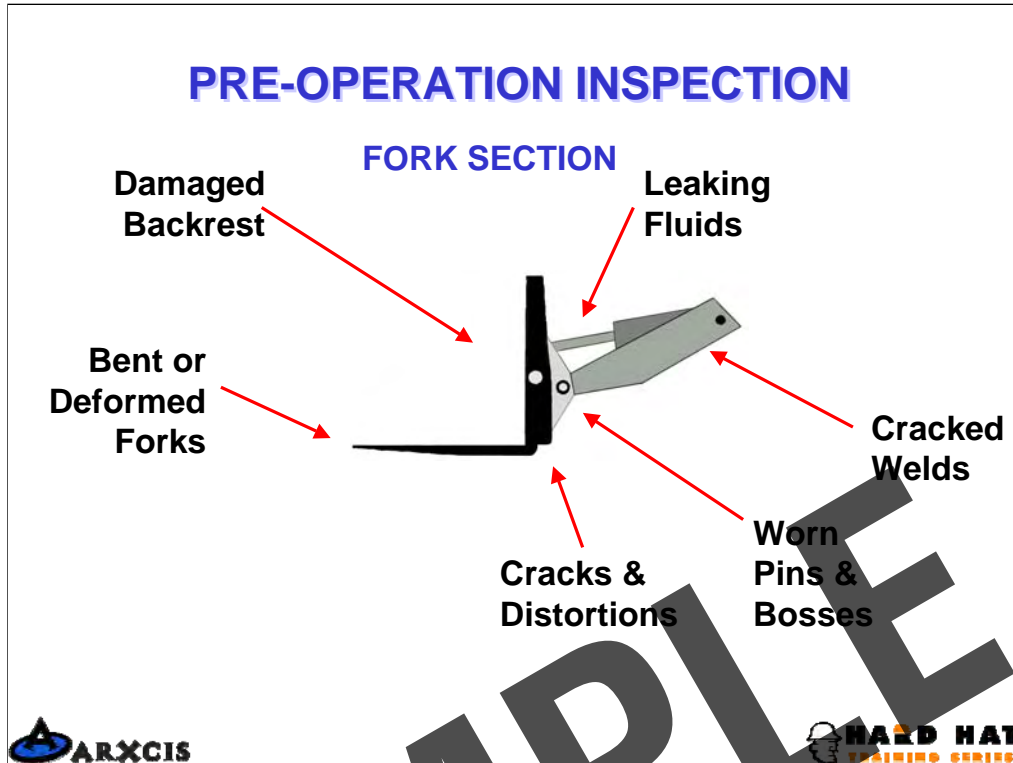

**OBJECTIVE:** To review the inspection criteria for the forks.

1. Inspect the forks for bends. Both forks should be parallel.
2. Check the back of the forks for cracks at the 90 degree bend.
3. Inspect the backrest area for damage.
4. The tilt hydraulic cylinder should be free of leaks. Check for worn hoses
5. Check all pins and bosses for wear.
6. Check all the welded areas for cracks.

## PRE-OPERATION INSPECTION

### Operational Inspection

- **Seat Belt**
- **Horn**
- **Warning Devices**
- **Gauges**
- **Hydraulic System & Controls**
- **Steering Mechanism**
- **Parking Brake**
- **Frame Sway Control**
- **Service Brakes**



OBJECTIVE: To review the items which should be checked for proper function.

1. Seat belts, if provided, need to be functioning properly.
2. Warning devices, including horns, lights and other devices must be operational.
3. All gauges should be checked for normal operations.
4. All the hydraulic functions need to be checked. The boom should be fully extended and retracted to ensure it operates smoothly.
5. Verify all of the steering functions are working properly.
6. Test the parking brake and the service brake to make sure they are functioning properly.
7. Test the sway controls.
8. Any control that functions erratically or is slow to respond needs to be repaired.

## COMPLETION OF INSPECTION

- Report All Defects To Appropriate Individuals
- Never Operate A Telescopic Handler In Need Of Repair
- Only Authorized & Trained Personnel Make  
Repairs



OBJECTIVE: To review what to do if a defect is identified.

1. If a company policy exists for reporting defects, discuss this with the student.
2. If no policy exists, then discuss to whom the defects need to be reported to.
3. The law states that a telescopic handler will not be operated which is not safe. Management is responsible for seeing that unsafe equipment is not used.

## TELESCOPIC HANDLER STABILITY & CAPACITY

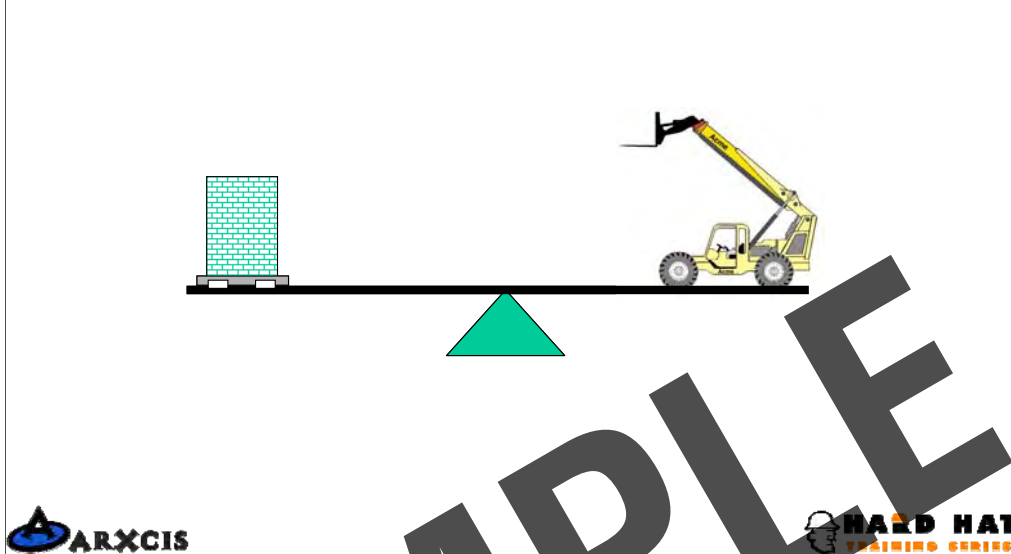

THIS NEXT SECTION DISCUSSES THE STABILITY OF THE TELESCOPIC HANDLER WHEN LIFTING AND MOVING LOADS.

## LOAD'S CENTER OF GRAVITY

**A point in the load around which all weight is evenly distributed**

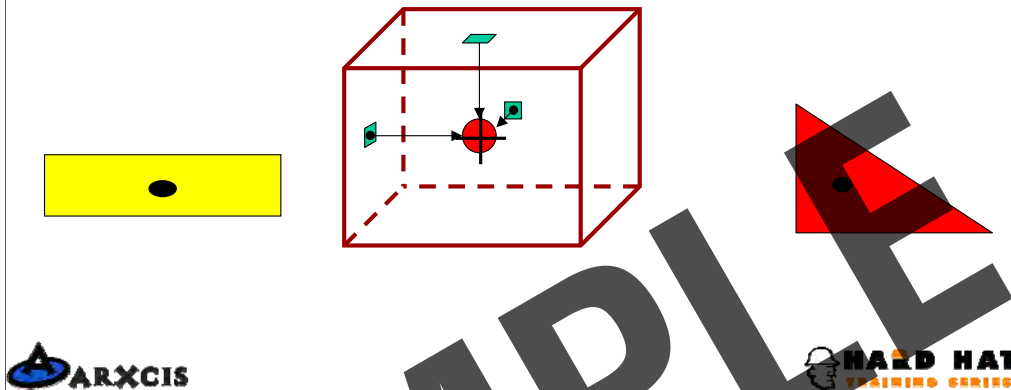

**PURPOSE:** Introduce the concept of “center of gravity.”

- Using a box as a visual aid, help the student to visualize where the center of gravity may be located in a load.
- The point in the load around which all weight is evenly distributed, even if the load is irregularly shaped.

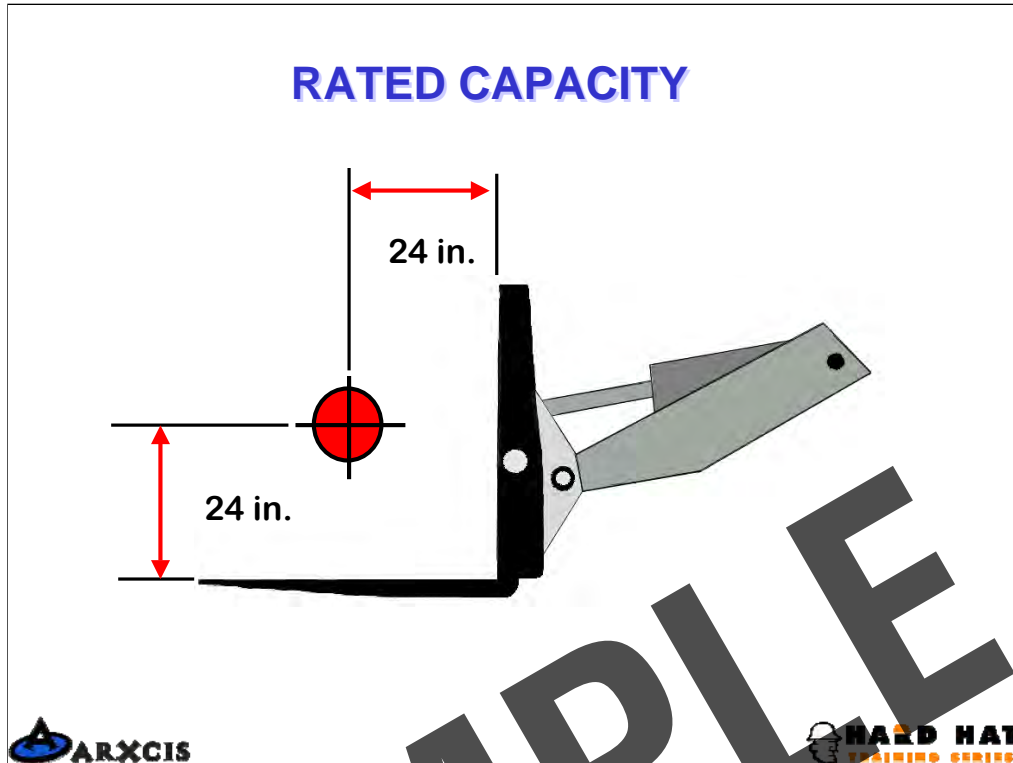

**PURPOSE:** To understand what is meant by the term “Load Center.”

- The manufacturer rates the capacity of the telescopic handler for a specific weight located at a specific point on the forks.
- If the load’s center of gravity varies from this specific “load center” then the capacity of the telescopic handler changes.

## TELESCOPIC HANDLER STABILITY

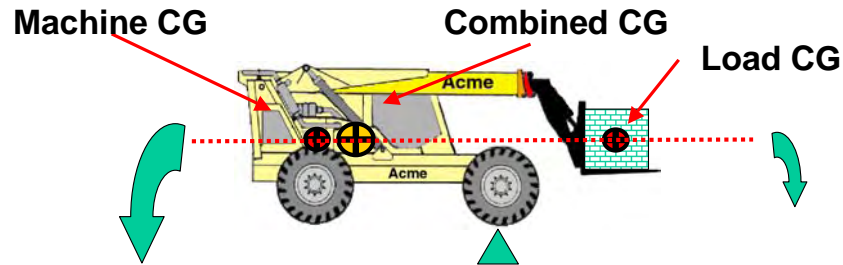

**Weight Behind The Front Axle Offsets  
The Weight In Front Of The Axle**



**OBJECTIVE:** To review the basic principles of balance as they apply to the telescopic handler.

1. Point out that the front wheels are the pivot point of balance in the fore and aft directions.
2. The machine's center of gravity (CG) will be somewhere in the vicinity of the engine. The weight of the machine behind the front axle times the distance from the front axle to the machine's center of gravity produces the off setting torque.
3. The weight of the boom, forks, and the load ahead of the front axle times the distance from the front axle to the load produces a tipping torque.
4. The off setting torque must always be greater than the tipping torque.
5. The off setting torque is basically fixed and remains constant. The tipping torque can be increased by increasing the load weight or extending the boom out or both.
6. When the load is lifted, a combined center of gravity is produced and will always be on a straight line between the load's CG and the machine's CG.

## CHANGING STABILITY

Combined CG is always on the line between load & machine CGs

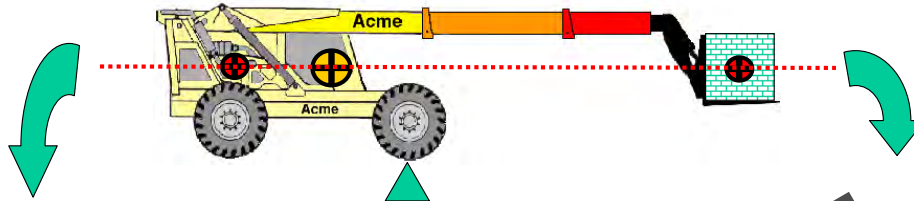

As the load moves farther from the pivot point the combined CG moves forward.



OBJECTIVE: To show how the combined center of gravity changes as the load is moved.

1. The combined CG will move forward as the load is moved forward by extending the boom.
2. If the combined CG moves past the front wheels, the machine will tip forward.

## CHANGING STABILITY

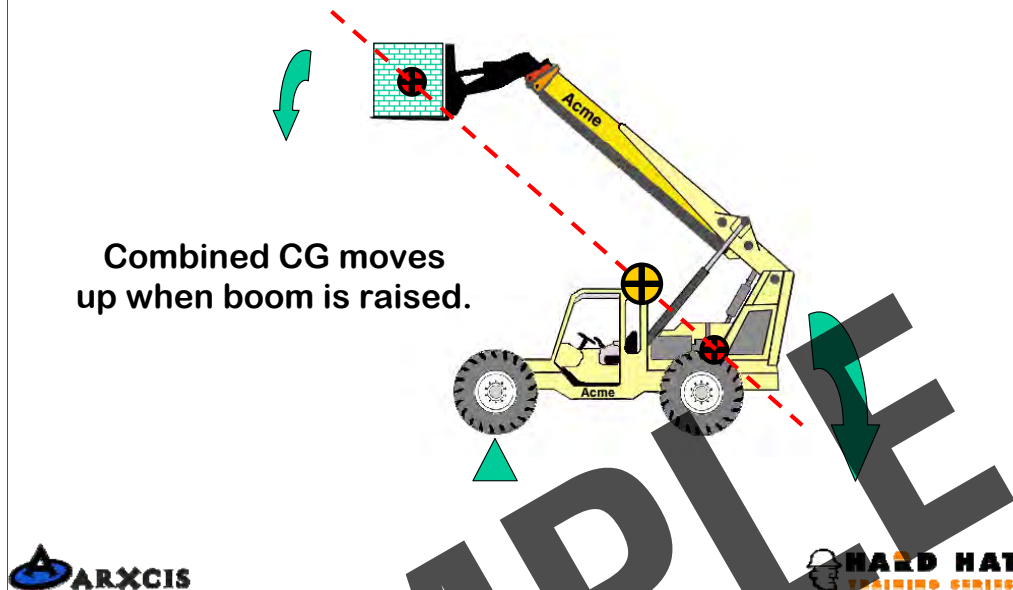

OBJECTIVE: To show how the combined center of gravity changes as the load is raised.

1. As the load is raised, the combined CG will move upward also.
2. Note that the combined CG will move backwards slight when the boom is raised but not extended.
3. A high combined CG has its greatest impact on stability when the machine is moving.

## CHANGING STABILITY

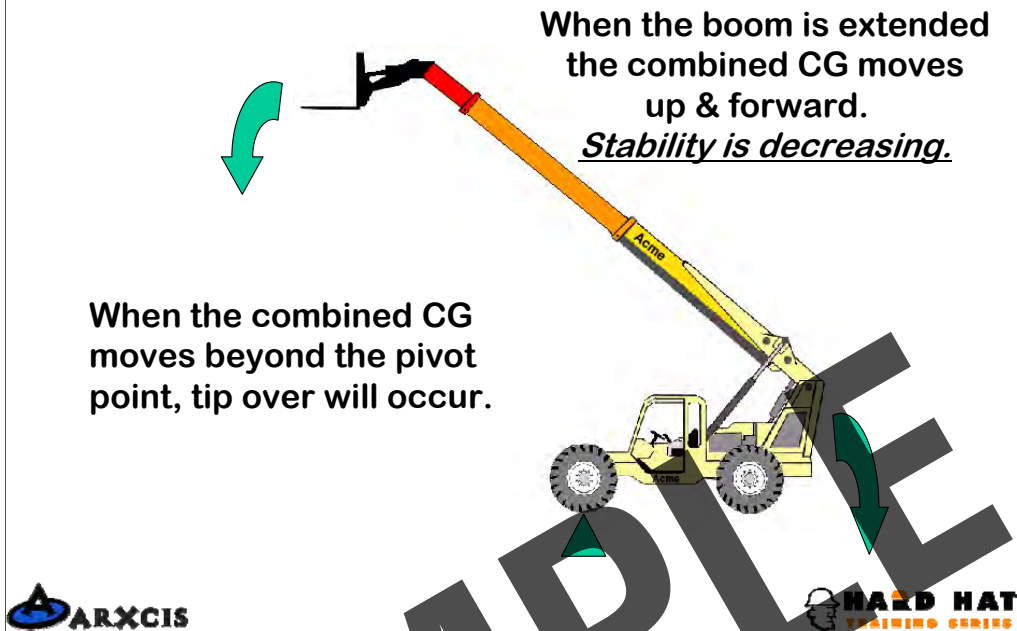

OBJECTIVE: To show how the combined center of gravity changes as the load is raised and extended.

1. Extending the boom with a heavy load will result in the machine tipping forward if the tipping torque becomes greater than the offsetting torque.
2. Operators need to be cautioned that a load which is stable close to the machine will become less stable as the boom is extended.
3. The weight of the load along with the load chart needs to be taken into consideration before extending a load.

## LIFT CAPACITY CHART

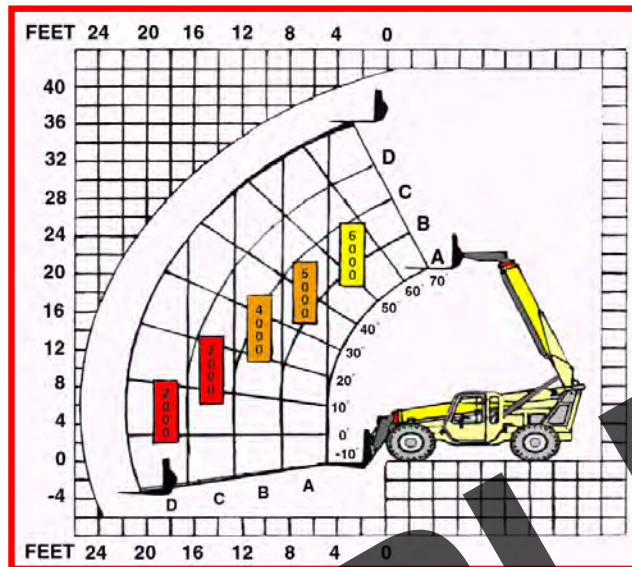

OBJECTIVE: To show how to use the lift capacity chart.

1. Review each part of the chart including the notes sections.
2. Emphasize that when a letter becomes visible on the boom as it is extended, the lift capacity then is reduced to the next lower capacity, regardless of how little the boom is extended beyond the visibility of the letter.
3. Again discuss why the lift capacity decrease as an extend boom is lowered.

The reason is that the tipping torque increases due to the horizontal distance between the load's CG and the front axles is increasing.

4. Point out that the lifting capacity shown is for the machine being perfectly level, on a solid surface, and no wind.

## LIFT CAPACITY CHART

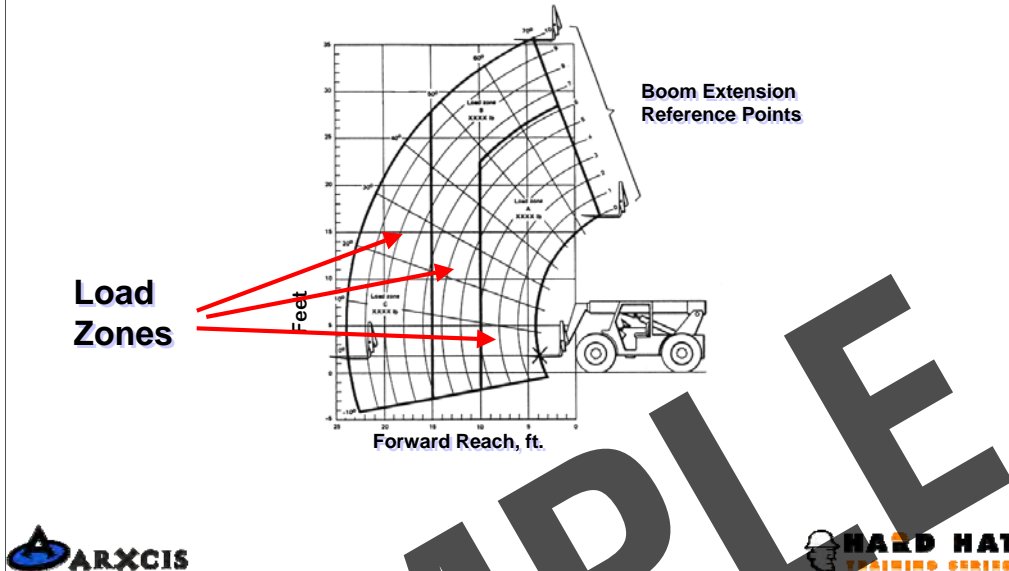

OBJECTIVE: To review the section of the lift capacity chart.

1. The lift capacity chart must be legible and visible to the operator.
2. The chart shows the machines lifting capacity at different boom lengths and boom angles.
3. Review the diagram with the students making sure that they understand each part of the chart.

## LIFT CAPACITY CHART

**Lift Capacity  
Stabilizers Down**

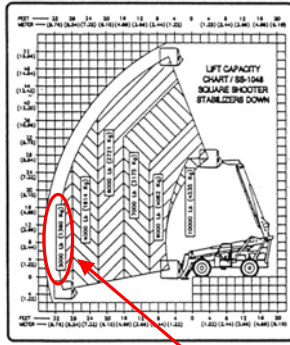

**3000 LBS**

**Lift Capacity  
Stabilizers Up**

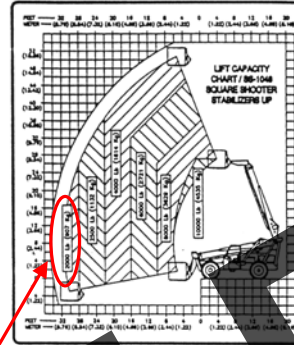

**2000 LBS**



OBJECTIVE: To show how the lifting capacity changes when stabilizers are used.

1. This applies only to machines which have stabilizers.
2. Note how the lift capacity increases when the stabilizers are properly deployed.
3. The operator needs to make sure he is referencing the correct chart when determining his load limits.

## EFFECTS OF STABILIZERS

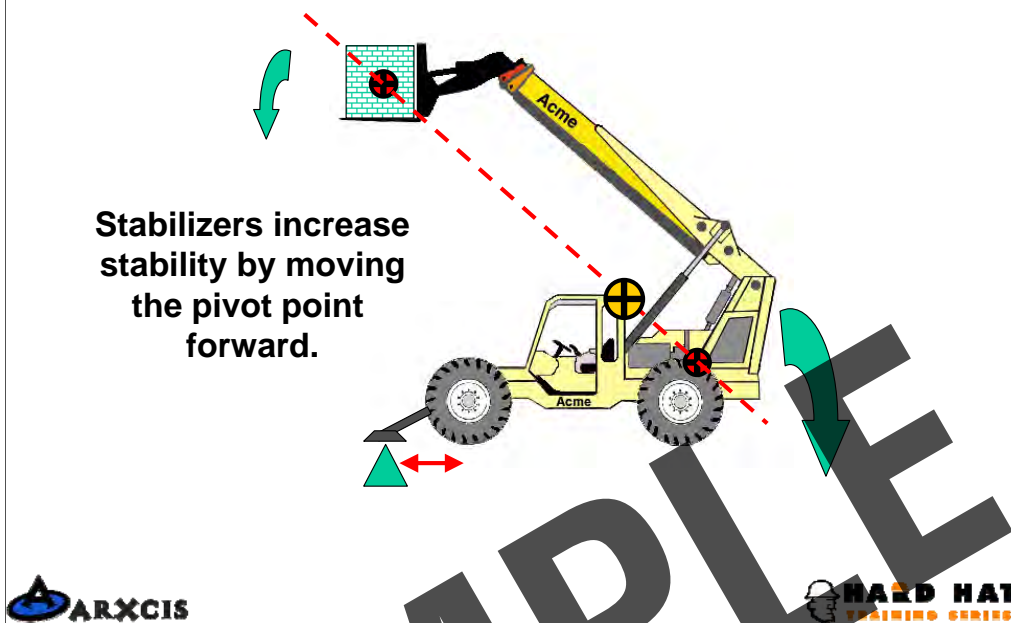

OBJECTIVE: To show how stability is affected by the use of the stabilizers.

1. Using the stabilizers increases the machine's lifting capacity.
2. When making a maximum lift with the stabilizers down, the operator must make sure the load is retracted sufficiently before raising the stabilizers. If not, the machine could tip forward.

## ATTACHMENTS TO THE TELESCOPIC HANDLER

The capacity of the telescopic handler is affected any time an attachment is added to the machine.

### The attachment will:

- Add weight to the front of the machine causing it to be partially loaded
- The additional weight may extend the load center

### If you want to add an attachment to the telescopic handler after you receive it from the manufacturer, you must:

- Have written approval from the manufacturer
- Have a new capacity plate installed on the telescopic handler indicating the new capacity when using the attachment. The plate is only available from the manufacturer.



**PURPOSE:** Help the students understand that attachments of any type need to be approved by the manufacturer.

- Attachments alter the telescopic handler's load capacity and stability.
- The warning plate needs to be changed to reflect the telescopic handler's current configuration.

## ATTACHMENTS TO THE TELESCOPIC HANDLER



SAMPLE

## DYNAMIC AND STATIC CONDITIONS

The telescopic handler's balance is affected by both **static** and **dynamic** conditions. Static conditions are those which affect the telescopic handler when it is not moving. Dynamic conditions are created when the telescopic handler is moving.

### Static conditions include:

- Load size
- Load shape
- Position of load on forks
- Lift height
- Amount of tilt
- Tire pressure

### Dynamic conditions include:

- Acceleration
- Speed
- Braking
- Ramps and slopes
- Raising load
- Lowering load



**PURPOSE:** To show how other conditions can affect the stability of the telescopic handler.

- Static conditions are those that remain constant regardless of motion.
- Dynamic Conditions are created as the telescopic handler moves and as the load is moved around.

- Acceleration and braking can cause additional load forces to be placed on the telescopic handler. Emphasis how braking can cause the telescopic handler to tip forward. This affect is increased as the load is raised.

- Uneven surfaces can also cause the telescopic handler to become unstable - again the degree of instability is primarily affected by the height of the load.

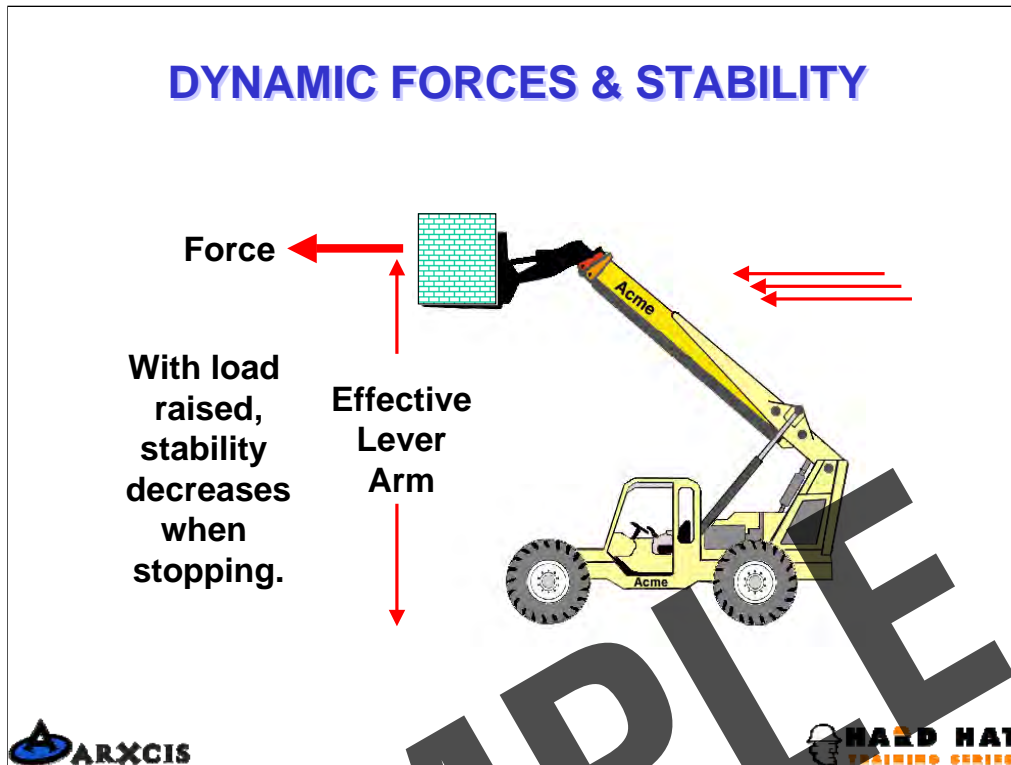

**OBJECTIVE:** To show how dynamic forces affected the machine's stability.

1. The law of motions states basically that an object at rest wants to remain at rest and an object in motion wants to remain in motions unless acted upon by an external force.
2. These two laws impact the stability of the machine when moving a load.
3. When a telescopic handler that is transporting a load stops, the load wants to continue moving. The additional force created by this movement will want to tip the machine forward.
4. The pivot point for this tipping motion is the front wheels and the distance from the ground to the load center is the effective lever arm. The forward motion of the load times the effective lever arm will produce a dynamic tipping torque. This dynamic tipping torque is added to the static tipping torque which the off setting torque must oppose or the machine will tip over.
5. The amount of forward force is dependent on how fast the machine is stopped. Braking fast will create greater tipping torque while slowly coming to a stop will produce a small tipping torque.

## DYNAMIC FORCES & STABILITY

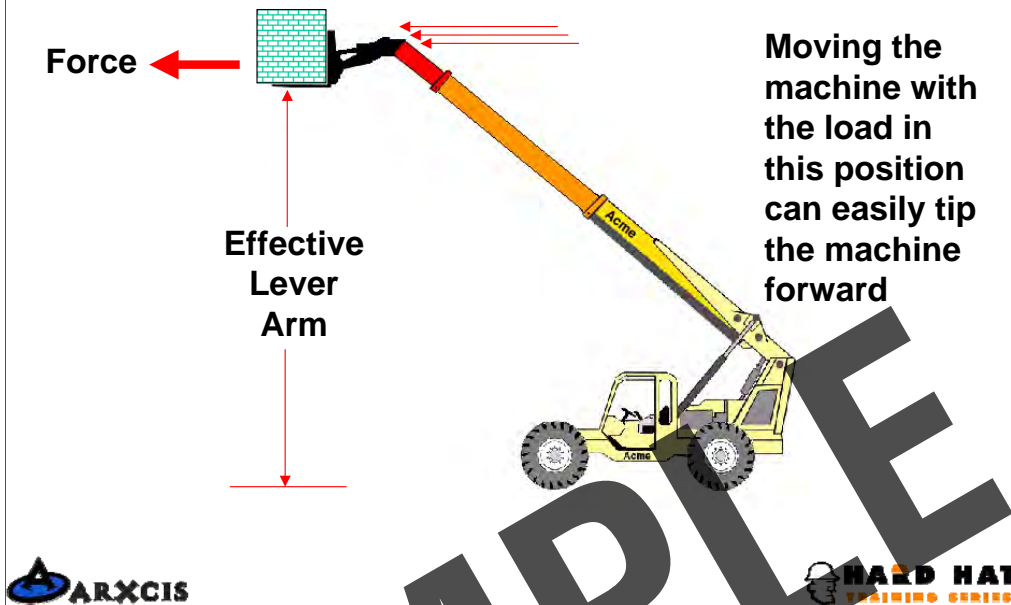

OBJECTIVE: To show how dynamic forces affected the machine's stability.

1. The higher the load is elevated, the greater the effective lever arm and therefore the greater the dynamic tipping torque will be.
2. The higher the load is carried when transporting it, the greater the risk for a tip over.

## DYNAMIC FORCES & STABILITY

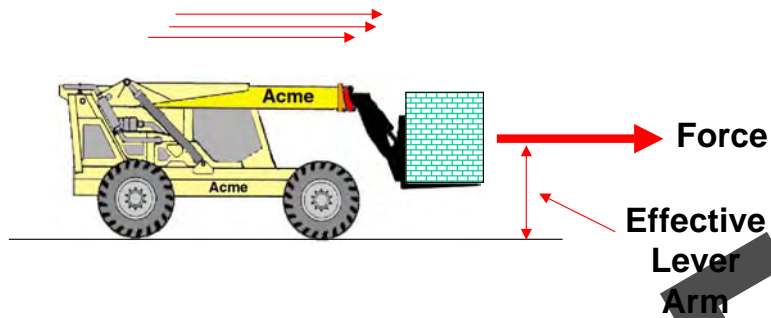

Moving the machine with the load low has minimal effect on stability.



OBJECTIVE: To show how dynamic forces affected the machine's stability.

1. Note how small the effective lever arm is when the load is carried low.
2. The dynamic tipping torque for this situation is small and thus the machine is much less likely to tip over when braked.

## DYNAMIC FORCES & STABILITY

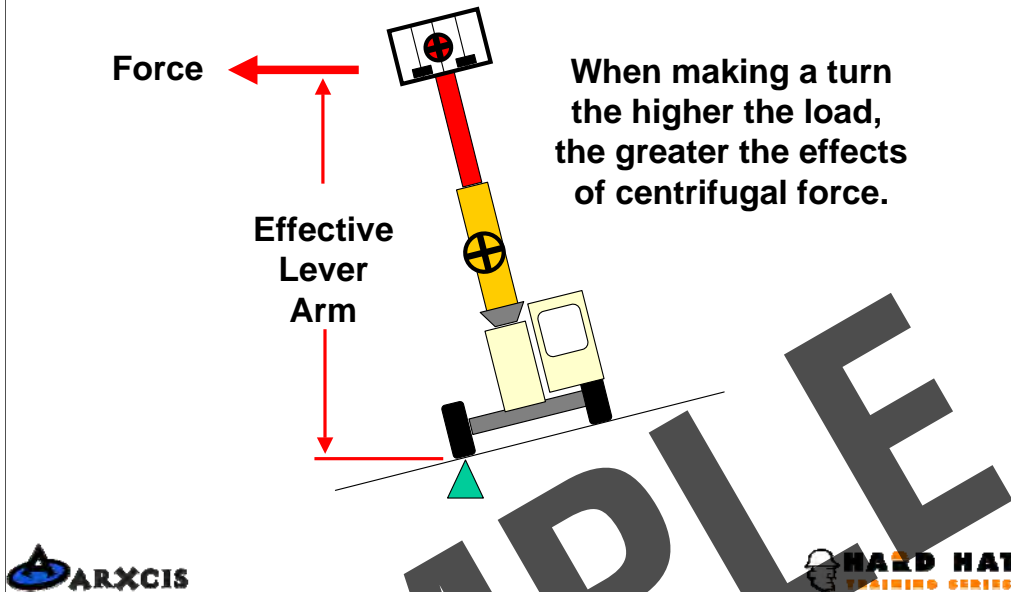

OBJECTIVE: To show how dynamic forces affected the machine's stability.

1. The machine's lateral stability can be affected by dynamic forces created when making a turn.
2. Making a turn with the load raised high allows the centrifugal force to create a greater dynamic tipping torque than if the load is low.
3. This problem is compounded when the machine is making an up hill turn.

## LATERAL STABILITY

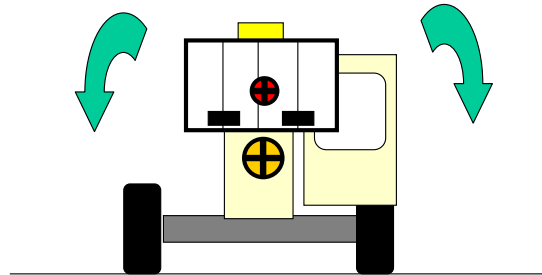

On level ground, the combined CG will be on the machine's center line.



OBJECTIVE: To show how the lateral stability changes as the load is moved.

1. Lateral stability is the stability of machine from side to side.
2. When the load is carried low to the level ground, the combined CG will be on center line.
3. This is the most stable positions for traveling with the load.

## LATERAL STABILITY

When the load is elevated on level ground, the combined CG will remain on the machine's center line.

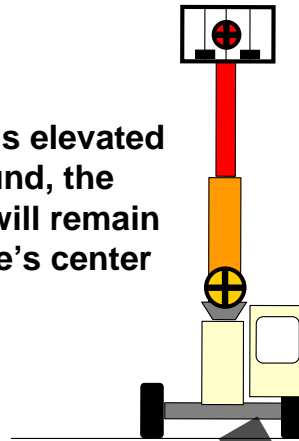

OBJECTIVE: To show how the lateral stability is affected by the changing combined center of gravity as the load is raised.

1. When the load is raised on level ground and no wind is present, the combined CG will remain on the machine's center line.
2. Point out that this is only true when the machine is level.

## LATERAL STABILITY

When the load is kept low lateral stability remains good even on unlevel surfaces.

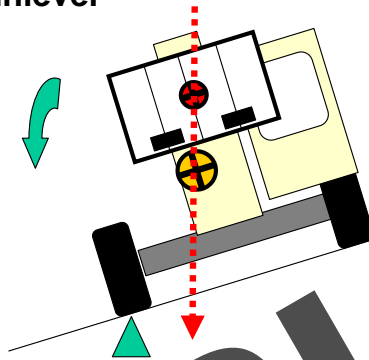

OBJECTIVE: To show how the lateral stability is affected when the machine is operated on unlevel surfaces.

1. Note how the combined CG moves toward the down slope wheels which become the pivoting point.
2. If the slope became steep enough, the combine CG will move past the wheels and the machine will roll over.

## LATERAL STABILITY

When the load is raised on unlevel surfaces, the combined CG moves up and comes closer to the pivot point.

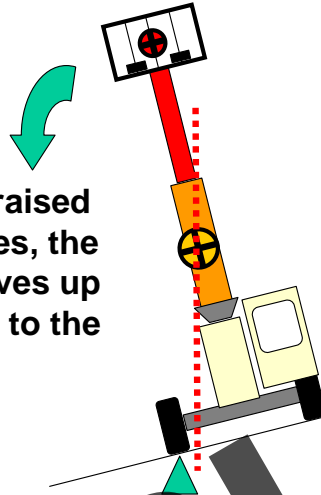

OBJECTIVE: To show how the lateral stability is affected when the machine is operated on unlevel surfaces with boom extended and raised.

1. Point out that the combined CG moves upward as the load is raised. Because the machine is on a slope, the CG moves toward the direction of the pivot point wheels more rapidly and can result in a tip over.
2. For the same slope, the elevated load is more likely to cause a tip over than a load in the lowered position.

## LATERAL STABILITY

Leveling the machine will move the combined CG away from the pivot point.

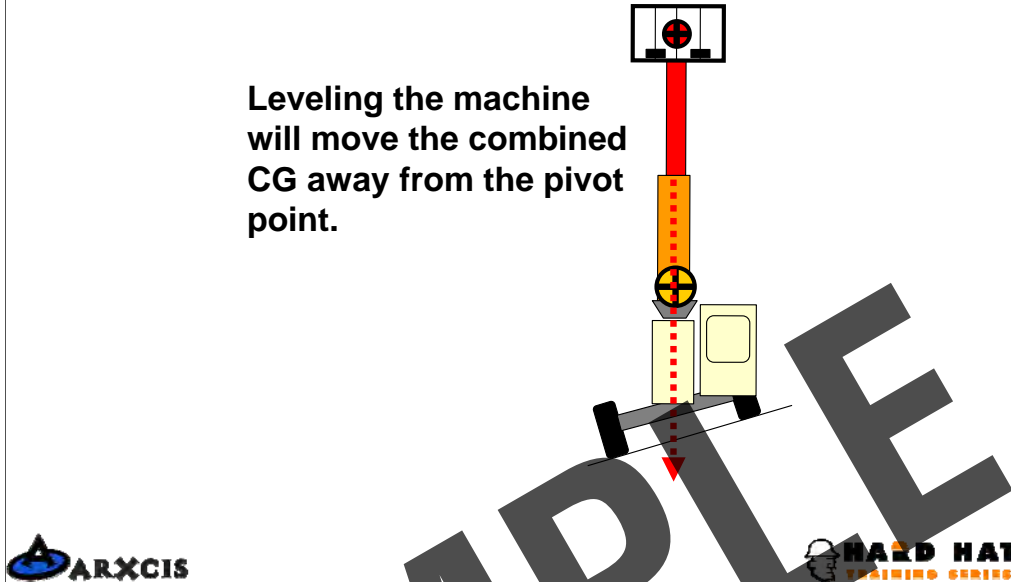

OBJECTIVE: To show how the lateral stability is restored when the machine is leveled using the sway control.

1. Leveling the machine with the sway control will move the combined CG back toward the machine's center line.
2. The machine's lateral stability is restored.

## LIFTING SUSPENDED LOADS

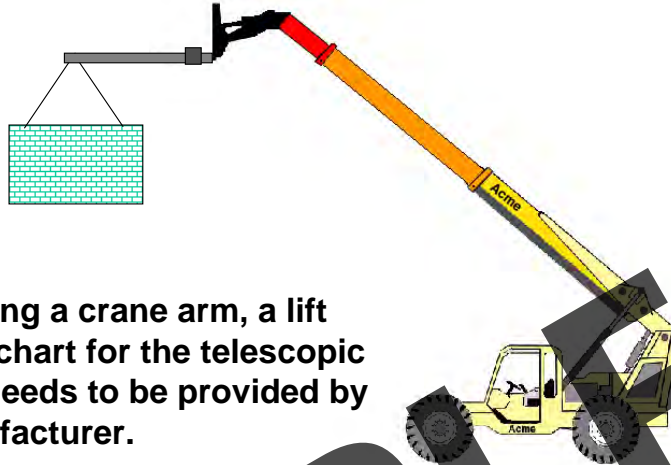

When using a crane arm, a lift capacity chart for the telescopic handler needs to be provided by the manufacturer.



**OBJECTIVE:** To discuss the problems associated with using the telescopic handler in crane mode.

1. When placing a crane arm on the telescopic handler for lifting suspended load, the manufacturer needs to be consulted to determine the new lifting capacities.
2. Traveling with suspended loads can cause additional dynamic forces which can result in a tip over.
3. Care must be used to prevent the load from striking the boom. This could result in the boom collapsing.
4. A lift capacity chart must be on the machine when such lifts are made.
5. Crane arms must be engineered with an established capacity identified.

## LIFTING SUSPENDED LOADS

Using the telescopic handler to move a suspended load needs to be done per the manufacturer's recommendations.

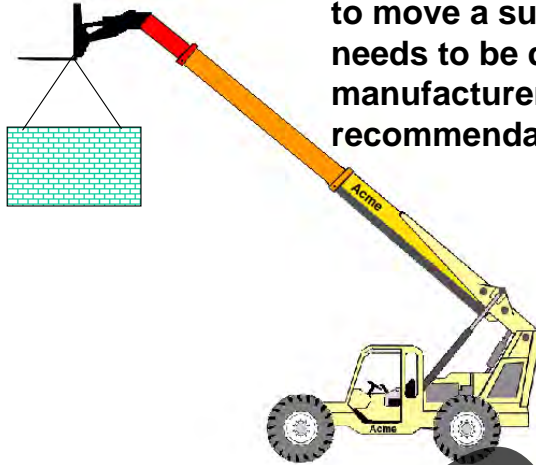

OBJECTIVE: To discuss the problems associated with using the telescopic handler in crane mode.

1. Lifting a load with a sling attached to the forks can create excessive stress on the forks.
2. Placing a hole at the end of the forks for attaching loads is not an acceptable means for lifting a load.
3. Slings placed on the forks can be damaged and they can slip off the forks.

## SOIL BEARING STRENGTH & STABILITY

Stability also depends  
the strength of the soil  
to support the front  
tires or stabilizers.



OBJECTIVE: To show how soil strength can affect the machine's stability.

1. As the load is extended forward, the combined CG moves forward transferring more weight to the front wheel.
2. The stability of the machine can change dramatically if the pressure on the soil by the tires is greater than the soil strength.
3. Exceeding the soil strength will result in the tires sinking which could cause the machine to tip forward or over to the side.

## SOIL BEARING STRENGTH & STABILITY



When the combined CG moves forward the loading on the front tires and the supporting soil increases.

Soil Loading



OBJECTIVE: To show how soil strength can affect the machine's stability.

1. When the boom is extended, the pressure on the soil under the front wheels increases.

SAMPLE

## SOIL BEARING STRENGTH & STABILITY

Soil Type	lbs/sq. in.	Conditions
Sound Rock	833	
Medium Rock	555	
Interm. Rock	277	
Porous Rock	28 - 111	
Hard Pan	166	Well Cemented
Hard Pan	111	Poorly Cemented
Gravel Soils	139	Compact, Well Graded
Gravel Soils	111	Compact w/ more than 10% gravel
Gravel Soils	83	Loose, Poorly Graded
Gravel Soils	55	Loose, Mostly Sand
Sand Soils	42 - 83	Dense
Fine Sand	28 - 55	Dense
Clay Soil	69	Hard
Clay Soil	28	Medium Stiff
Silt Soil	42	Dense
Silt Soil	21	Medium Dense
Compacted Fill	28 - 55	By Test Only



OBJECTIVE: To show how soil strength can affect the machine's stability.

1. This chart shows the soil strength of various types of soils.
2. The purpose of this chart is to show how soil strength can change.
3. Typically, the soil strengths around construction sites is poor because it has been disturbed.

## SAFE OPERATING GUIDELINES

### OPERATOR QUALIFICATIONS

- Only trained and authorized operators shall be permitted to operate a telescopic handler.
- Operators of telescopic handlers shall be qualified as to visual, auditory, physical, and mental ability.



OBJECTIVE: To discuss the basic requirements for elevating people.

1. Review these requirements with the students.

## OPERATOR TRAINING

- The user shall ensure that operators understand that safe operation is the operators responsibility.
- An effective operator training program should center around user's company policy, operating conditions, and telescopic handlers.
- The training should be presented completely to all new operators and not be condensed for those claiming previous experience.



OBJECTIVE: To discuss the basic requirements for operating a telescopic handler.

1. Review the above requirements with the students.
2. A review of the company policy regarding telescopic handler operations could be reviewed here.

## SAFE OPERATING GUIDELINES

- Safe operation is the responsibility of the operator.
- The operator shall develop safe working habits.
- He shall be familiar with all controls and instruments.
- He shall be familiar with the Operators Manual.



OBJECTIVE: To discuss the basic operator responsibilities.

1. Review these responsibilities with the students.

## SAFE OPERATING GUIDELINES

- Before beginning to operate telescopic handler:
  - a) fasten seat belt, if so equipped;
  - b) place directional controls in neutral;
  - c) disengage clutch on manual transmission, or apply brake on power shift or automatic;
  - d) start engine.



OBJECTIVE: To discuss the basic operator responsibilities.

1. Review these responsibilities with the students.

## SAFE OPERATING GUIDELINES

- Do not start or operate telescopic handler, any of its functions, or attachments from any place other than the designated operators position.
- Keep hands and feet inside the compartment.
- Never put any part of the body into the mast structure or within the reach mechanism or other attachments.
- Check clearance under electrical wires, bridges, etc.



OBJECTIVE: To discuss the basic operator responsibilities.

1. Review these responsibilities with the students.

## SAFE OPERATING GUIDELINES

- Understand limitations of telescopic handler so as not to cause injury to personnel.
- Do not drive telescopic handler up to anyone standing in front of an object.
- Exercise care at cross-aisles, doorways, and other locations where pedestrians may step into the path of travel.



OBJECTIVE: To discuss the basic operator responsibilities.

1. Review these responsibilities with the students.

## SAFE OPERATING GUIDELINES

- Do not allow anyone to stand or pass under the elevated portion of the telescopic handler, whether empty or not.
- Do not permit passengers to ride on the telescopic handler unless a safe place has been provided by the manufacturer.
- Maintain a safe distance from the edge of ramps, platforms, and other similar working surfaces.
- Do not block access to fire aisles, stairways, and fire equipment.



OBJECTIVE: To discuss the basic operator responsibilities.

1. Review these responsibilities with the students.

## SAFE OPERATING GUIDELINES

### Attended vs Unattended Parking

- A telescopic handler is **attended** when the operator is less than 25 ft from the truck which remains in his view.
- A telescopic handler is **unattended** when the operator is 25 ft or more from the truck, or is out of view of the truck.



OBJECTIVE: To discuss the basic operator responsibilities.

1. Review these responsibilities with the students.
2. Attended parking: Transmission in neutral, park brake set, forks on the ground.
3. Unattended parking: Same as attended with the engine shut off and wheels blocked if on an incline.
4. The following slide details these requirements.

## SAFE OPERATING GUIDELINES

Before leaving the operators position:

- put telescopic handler in neutral;
- apply parking brake;
- fully lower the forks.

In addition, when leaving the telescopic handler unattended:

- stop engine;
- if on an incline, block wheels.



OBJECTIVE: To discuss the basic operator responsibilities.

1. Review these responsibilities with the students.

## TRAVELING

When traveling on public roads or changing job sites:

- If telescopic handler is equipped with individual wheel brake pedals, lock pedals together for simultaneous operation.
- If telescopic handler has a differential lock, the lock should not be engaged when driving on the road or at high speeds or when turning. There could be loss of steering control.



OBJECTIVE: To discuss the basic operator responsibilities.

1. Review these responsibilities with the students.

## TRAVELING

When traveling on public roads or changing job sites:

- observe all traffic regulations
- keep to the right
- maintain safe distance from other vehicles
- keep truck under control at all times
- yield right of way to pedestrians
- yield right of way to emergency vehicles
- cross railroad tracks at an angle if possible



OBJECTIVE: To discuss the basic operator responsibilities.

1. Review these responsibilities with the students.

## TRAVELING

- Keep a clear view of path of travel
- If the load obstructs your view, travel in reverse or use a spotter
- Travel at a speed that will permit it to be stopped in a safe manner.
- Travel with the forks or load tilted back if possible
- Do not elevate the load except when stacking



OBJECTIVE: To discuss the basic operator responsibilities.

1. Review these responsibilities with the students.

## TRAVELING

- Make starts, stops, turns, or directional reverses in a smooth manner so as not to shift load or overturn the truck.
- Slow down on wet or slippery surfaces
- Do not indulge in stunt driving or horseplay
- Avoid running over loose objects on the ground
- Lateral turnover is greater when forks are empty



OBJECTIVE: To discuss the basic operator responsibilities.

1. Review these responsibilities with the students.

## TRAVELING

When negotiating turns:

- know which steering mode you are in
- before changing modes, align back wheels
- reduce speed to a safe level
- turn steering wheel in a smooth, sweeping motion
- never turn while the load is elevated except at very slow speeds, turn steering wheel at a moderate, even rate



OBJECTIVE: To discuss the basic operator responsibilities.

1. Review these responsibilities with the students.

## TRAVELING

Ascending or descending grades:

- on grades of 5% or more, load should be upgrade
- empty forks should be downgrade
- on all grades, the load should be tilted back and raised only enough to clear the road surface
- avoid turning, if possible, normally travel straight up and down



OBJECTIVE: To discuss the basic operator responsibilities.

1. Review these responsibilities with the students.

## LOADING

- use stabilizer controls only in compliance with the manufacturer's instructions
- for telescopic handlers that are equipped with lateral leveling:
  - always level the frame before raising boom
  - lateral leveling should never be used to position an elevated load



OBJECTIVE: To discuss the basic operator responsibilities.

1. Review these responsibilities with the students.

## LOADING

- handle only stable or safely arranged loads
- when using attachments, make sure they are properly used and secured
- complete engage load with forks at least 2/3 under the load
- use extreme care when tilting the load forward



OBJECTIVE: To discuss the basic operator responsibilities.

1. Review these responsibilities with the students.

## ELEVATING PERSONNEL

A telescopic handler should not be used to lift people unless there is no other practical option and approved by the manufacturer.

If it must be used to elevate people, the following precautions for the protection of personnel shall be taken:



OBJECTIVE: To discuss the basic requirements for elevating people.

1. Any time a machine is used to elevate people special requirements need to be met.
2. Some telescopic handler manufacturers explicitly restrict their machine from lifting people. These restrictions are legally binding and should not be ignored.

## ELEVATING PERSONNEL

- Provide an ASME approved personnel platform that is securely attached to the lifting carriage or forks.
- Be certain that the platform is horizontal and never tilt forward or rearward when elevated.
- Area should be marked to warn of elevated personnel.
- Provide protection for personnel, including: restraining means, overhead guard, and shielding from moving parts.



OBJECTIVE: To discuss the basic requirements for elevating people.

1. Review these requirements with the students.
2. Remember, the personnel platform used must be OSHA approved.

## ELEVATING PERSONNEL

- Be certain that the lifting mechanism is operating smoothly through its entire range.
- Be certain that the mast or boom travel is vertical.
- Be certain that the machine has a firm footing.
- Place machine control(s) in neutral and set brake.
- Make sure path of platform is clear of wires, racks, etc.



OBJECTIVE: To discuss the basic requirements for elevating people.

1. Review these requirements with the students.

## ELEVATING PERSONNEL

- Keep hands and feet clear of controls other than those in use.
- Lift and lower personnel smoothly, with caution, and only at their request.
- Always lower the platform if you must move the telescopic handler for repositioning. Alert personnel before moving.



OBJECTIVE: To discuss the basic requirements for elevating people.

1. Review these requirements with the students.

## ELEVATING PERSONNEL

- The combined weight of the platform, load, and personnel shall not exceed one-third of the capacity.
- Platform shall be lowered to floor level for entering and exiting.



OBJECTIVE: To discuss the basic requirements for elevating people.

1. Note the lift capacity restriction.

## POWERLINE CONTACT

### Required Clearances

50kV	10 ft
50 to 200kV	15 ft
200 to 350kV	20 ft

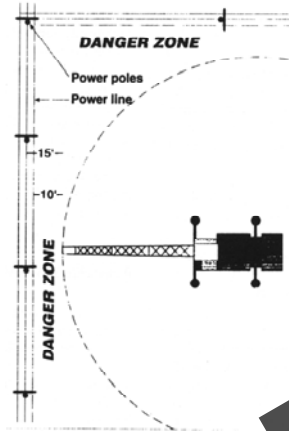

OBJECTIVE: To review the requirements for operating around power lines.

1. The minimum clearance requirements need to be observed.
2. It may be necessary to have an assigned spotter to watch the boom to ensure that it does not enter the danger zone.
3. Electrocution is the number one cause of death involving cranes.

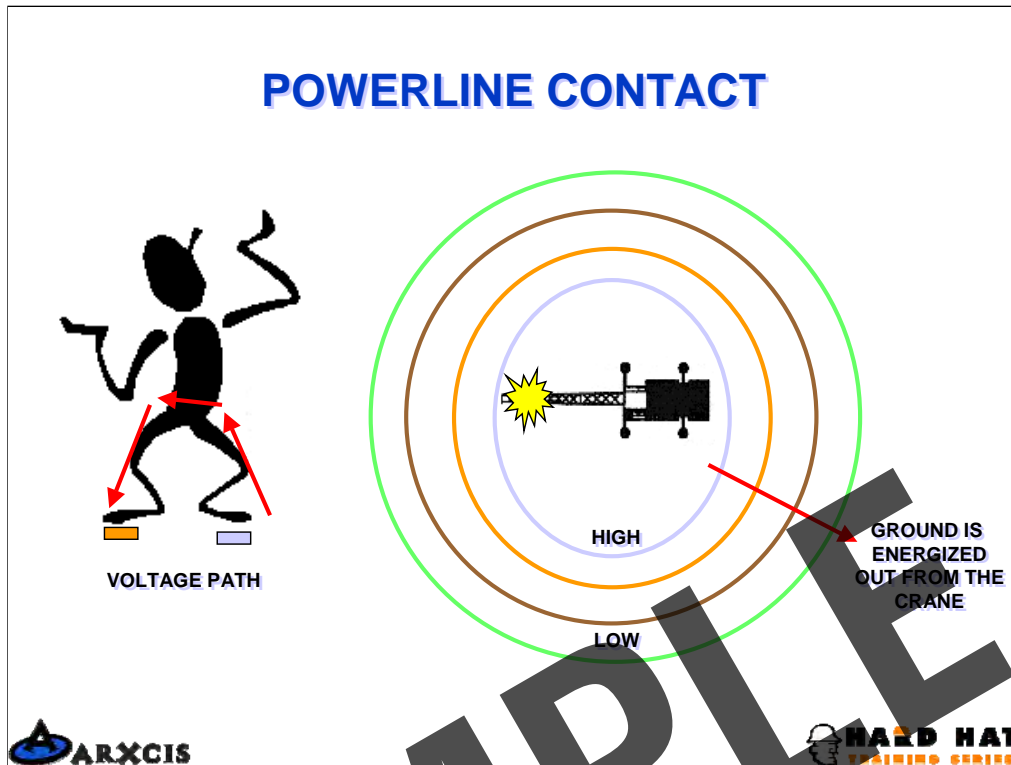

**OBJECTIVE:** To discuss what should be done in case of a power line contact.

1. The operator should remain with the machine if at all possible until the power company indicates it is safe to leave the telescopic handler. This is because the telescopic handler components could be at different voltage potentials and touching parts of the machine could result in being electrocuted.
2. No one should be allowed to approach the telescopic handler or to touch it. If the operator is unconscious, no attempt should be made to rescue him until the power company indicates it is safe to do so.
3. If the operator must leave the telescopic handler due to fire, he should shuffle to the edge of the platform he is standing on and carefully jump to the ground. It is important that he is able to land standing. Once on the ground, shuffle away from the telescopic handler.

## REFUELING THE TELESCOPIC HANDLER

- Refuel when the engine is cool
- In a designated area
- Fire extinguisher available
- Park in unattended mode
- Do not 'top off' the tank
- No smoking, flames, sparks
- Clean up spills



OBJECTIVE: To discuss the basic operator responsibilities when fueling.

1. Review these responsibilities with the students.
2. Add any additional requirements of the company and/or the manufacturer.

## CALCULATING LOAD WEIGHTS

### *Importance of load weights*

The weight of the load to be lifted must be known to prevent overloading of the telescopic handler. The load chart cannot be referred to and guessing can be dangerous.

**You must know the weight of the load to prevent tip overs!**

*If you must estimate, never boom out to a point where the weight would exceed 50% of the capacity of that load zone.*

In other words, make the best estimate you can and then multiply it by 2 to determine the safest load zone you can operate in.



SAMPLE

## CALCULATING LOAD WEIGHTS

### Acceptable methods of determining weight

You may find the weight from:

- Data on manufacturing label plates.
- Manufacturer documentation.
- Blueprints or drawings.
- Shipping receipts.
- Weigh the item.
- Bill of lading (be careful)
- Stamped or written on the load
- Approved calculations

*Never use word of mouth* to establish the weight of an item!



OBJECTIVE: To show the different means of determining the weight of a load.

**SAMPLE**

## CALCULATING LOAD WEIGHTS

### Calculating the weight

To find the weight of any item you need to know its volume and unit weight.

- Volume x Unit weight = Load weight
- Unit weight is the density of the material
- Unit weight is normally measured by pounds per cubic foot.



OBJECTIVE: To emphasize the importance of knowing how to calculate weights.

**SAMPLE**

Here are some examples of common materials and their unit weight:

<b>METALS</b>		<b>TIMBER</b>	
Aluminum	165	Cedar	34
Brass	535	Cherry	36
Bronze	500	Fir, seasoned	34
Copper	560	Fir, wet	50
Iron	480	Hemlock	30
Lead	710	Maple	53
Steel	490	Oak	62
Tin	460	Pine	30
<b>MASONARY</b>		Poplar	30
Ashlar masonry	160	Spruce	28
Brick, soft	110	White pine	25
Brick, pressed	140	Railroad ties	50
Clay tile	60	<b>LIQUIDS</b>	
Rubble masonry	155	Diesel	52
Concrete, cinder, haydite	110	Gasoline	45
Concrete, slag	130	Water	62
Concrete, stone	144	<b>EARTH</b>	
Concrete, reinforced	150	Earth, wet	100
<b>MISC.</b>		Earth, dry	75
Asphalt	80	Sand and gravel, wet	120
Glass	160	Sand and gravel, dry	105



OBJECTIVE: To show the unit weights for some common materials.

1. It's wise to have similar "cheat sheets" for materials that you handle frequently.

## CALCULATING VOLUME

### Volume of a cube

Length x Width x Height = Volume

$$8 \text{ ft} \times 4 \text{ ft} \times 2 \text{ ft} = 64 \text{ cubic feet}$$

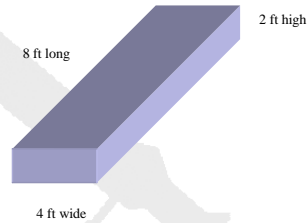

If the material was **cedar**, then all we would have to do to determine its weight would be to multiply the unit weight of cedar x 64.

Unit weight x Volume = Weight

$$34 \text{ lbs.} \times 64 \text{ cubic ft.} = 2,176 \text{ lbs.}$$



OBJECTIVE: To demonstrate how to calculate the volume of a cube.

1. Cubes are easy to calculate.
2. Finding the weight is as simple as multiplying the volume of the cube by the unit weight of what it is made of.

## CALCULATING VOLUME

### Volume of a cylinder

Pi x Radius Squared x Length = Volume

$\pi \times \text{Radius}^2 \times \text{Length} = \text{Volume}$

$3.14 \times 1^2 \text{ ft} \times 10 \text{ ft} = 31.4 \text{ cubic ft}$

If the material was **reinforced concrete**, then all we would have to do to determine it's weight would be to multiply the unit weight of reinforced concrete x 31.4.

$150 \text{ lbs.} \times 31.4 \text{ cubic ft.} = 4,710 \text{ lbs.}$

10 ft long

2 ft wide



OBJECTIVE: To demonstrate how to find the volume of a cylinder.

1. The volume of a cylinder is a little more difficult, but not rocket science. Having a scientific calculator and knowing how to use it is a good idea.
2. Again, just multiply the volume in cubic feet by the unit weight to find the weight of the load.

## CALCULATING VOLUME

### Volume of pipe

Calculating the volume of pipe is a bit trickier but it is just simply subtracting the volume of the hole from the volume of the pipe.

If the pipe were one inch thick, three feet wide and 8 feet long, then we would figure the volume of the entire pipe and subtract the volume of the hole to get the the volume of the material.

8 ft long  
1 in. thick  
3 ft wide

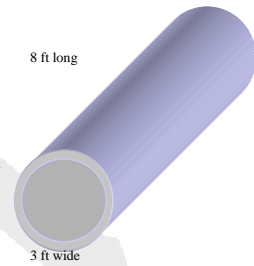

$$3.14 \times (1 \frac{1}{2} \text{ ft.})^2 \times 8 \text{ feet} = \text{total volume of pipe (56.52 ft}^3\text{)}$$

$$3.14 \times (1 \text{ ft } 5 \text{ in.})^2 \times 8 \text{ feet} = \text{volume of hole (50.41 ft}^3\text{)}$$

$$56.52 \text{ ft}^3 - 50.41 \text{ ft}^3 = 6.11 \text{ ft}^3$$

Volume of material x unit weight = total weight

If this pipe were **steel** then the unit weight would be 490 lbs.

$$6.11 \times 490 \text{ lbs} = 2,999 \text{ lbs.}$$



OBJECTIVE: To demonstrate how to find the volume of a pipe.

1. Finding the volume of a pipe is not too much different than finding the volume of a cylinder. You just have to do it twice and then subtract the volume of the hole from the total volume of the pipe.
2. It is helpful to know how to change fractions into decimals. Calculators are a must for this. To change 1 foot 5 inches (or 17/12ths) into a decimal, simple divide 12 into 17 which would be 1.4266.

## CALCULATING VOLUME

For thin pipe a quick way to **\*ESTIMATE** the volume is to split the pipe open and calculate the volume like a cube. The formula would be:

$\pi \times \text{diameter} = \text{width}$ , so:

$\pi \times \text{diameter} \times \text{length} \times \text{thickness} \times \text{unit weight} = \text{weight of object}$

$3.14 \times 3 \text{ ft} \times 8 \text{ ft} \times 1/12 \text{ ft (or .08 ft)} \times 490 \text{ lbs} = *3,077.2 \text{ lbs}$



OBJECTIVE: To demonstrate how to estimate the volume of thin pipe.

1. This is only an estimate and should not be used with thick pipe.
2. Simply spit the pipe down the middle and open it up into a thin plate.
3. Then calculate the the volume of the cube that is created.
4. To find the width, multiply pi times the diameter.

## WEIGHT TABLES

### WEIGHT TABLES

Weight tables are an excellent way to calculate load weight. If you are handling certain materials often, then having a chart that gives you the weight per cubic foot, cubic yard, square foot, linear foot or per gallon. Here are a few examples:

#### METAL PLATES

STEEL PLATES weigh approximately 40 lbs per sq. ft. at 1 inch thick. 1/2 inch thick would then be about 20 lbs. per sq. ft.

A steel plate measuring 8 ft. x 10 ft. x 1/2 inch would then weigh about 3,200 lbs.  
(8 x 10 x 40 lbs = 3,200 lbs.)

#### BEAMS

Beams come in all kinds of materials and shapes and lengths. STEEL I-BEAMS weigh approximately 40 lbs a linear ft. at 1 inch thick and 8 inches x 8 inches. If it were 1 inch thick then it would be 80 lbs a linear ft. If it were 20 feet long at 1 inch thick then it would weigh about 1,600 lbs.  
(20 ft. x 80 lbs. = 1,600lbs.)



OBJECTIVE: To encourage the use of weight tables for determining the weights of loads.

SAMPLE